

Internationally Approved
EN 15267 Certified



Continuous Emissions Monitoring
and Process Control

Fertilizer Production

Continuous Emissions Monitoring and Process Control

Fertilizer Production

Process control and emissions monitoring in a fertilizer plant can be a challenge due to the high concentrations of HF. To use an extractive system in this environment will demand a lot of maintenance.

The OPSIS DOAS system is different and provides fertilizer plants with an accurate analyser that will operate with a minimum of maintenance. The OPSIS DOAS system is based on a non-contact method using an optical measurement path that can operate across the duct.

The optical light is transported in an optical fibre to the analyser and one analyser can operate several paths.

A single OPSIS system can measure all relevant gas components such as NH₃, NO_x, HF.

RETURN OF INVESTMENT

The cost of investing in an OPSIS system is small compared to the amount of money that is spent on maintaining extractive measurement systems.

TEST AND APPROVALS

The OPSIS system has been tested and approved by a number of internationally recognized institutes and authorities. The system is approved by German TÜV, British MCERTS and U.S. EPA. Full details are available on request.

OPSIS PRODUCT PORTFOLIO

OPSIS has a full product portfolio for measurements of gases in a range of applications. It includes complete CEM systems according to the European waste directive, TDL systems, oxygen analysers and Hg analysers.

For further information, please visit www.opsis.se.

QAL 1 CERTIFICATION:

BEST PERFORMANCE

LONGEST CALIBRATION INTERVAL

SYSTEM OVERVIEW

An OPSIS system layout for monitoring in a fertilizer plant

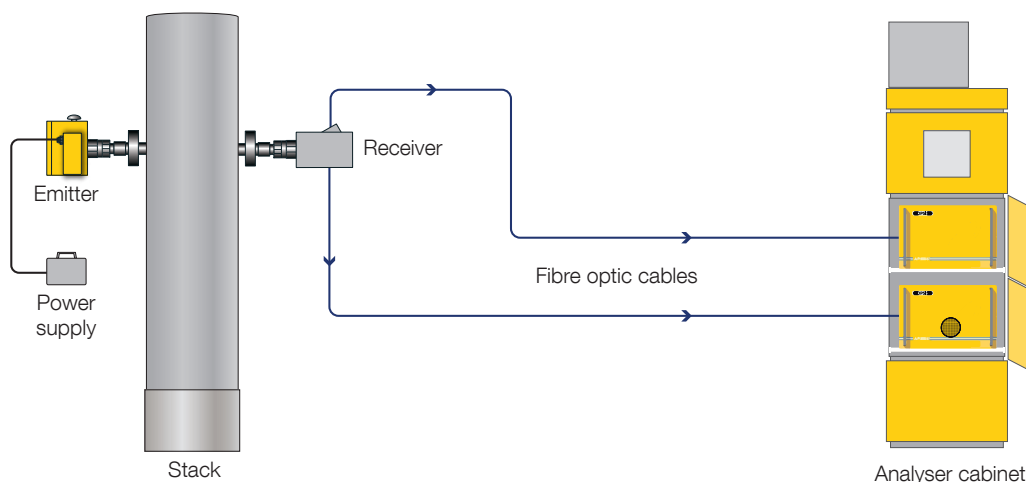

PERFORMANCE DATA

(typical data which may vary depending on application)

Compound	Max. measurement range (1 m path) ⁽¹⁾	Lowest measurement range according to EN 15267	Min. detectable quantities (monitoring path 1 m, measurement time 30 sec.)
UV/IR DOAS Analyser Models AR600 / AR602Z / AR602Z/Hg / AR602Z/N / AR602Z/NHg / AR620			
NO ₂ ⁽²⁾	0–2000 mg/m ³	0–150 mg/m ³	0.5 mg/m ³
NO ₂	0–100% Vol.	0–20 mg/m ³	0.5 mg/m ³
SO ₂	0–100% Vol.	0–75 mg/m ³	0.5 mg/m ³
NH ₃ ⁽³⁾	0–1000 mg/m ³	0–10 mg/m ³	0.5 mg/m ³
H ₂ O	0–100% Vol.	0–30% Vol.	0.1% Vol.
CO ₂	0–100% Vol.	0–30% Vol. ⁽⁵⁾	0.5% Vol.
FTIR DOAS Analyser Models AR650 / AR650/N			
HCl	0–5000 mg/m ³	0–15 mg/m ³	0.5 mg/m ³
CO	0–10000 mg/m ³	0–75 mg/m ³	2 mg/m ³
H ₂ O	0–100% Vol.	0–30% Vol.	0.1% Vol.
HF	0–1000 mg/m ³	0–1.5 mg/m ³	0.1 mg/m ³
NH ₃	0–1000 mg/m ³	0–100 mg/m ³ ⁽⁵⁾	2 mg/m ³
N ₂ O	0–10000 mg/m ³	0–500 mg/m ³	5 mg/m ³ ⁽⁴⁾
CH ₄	0–10000 mg/m ³	0–20 mg/m ³	0.5 mg/m ³
CO ₂	0–100% Vol.	0–20% Vol.	0.1% Vol.
LD500 Laser Diode Gas Analyser			
HF	0–100% Vol.	0–1.5 mg/m ³ ⁽⁵⁾	0.1 mg/m ³
NH ₃	0–100% Vol.	0–10 mg/m ³ ⁽⁵⁾	0.5 mg/m ³

Accuracy
Better than 2% of measured value or equal to the detection limit (whichever is greater).

Span drift
Less than 2% per year.
Please, refer to QAL1 documents.

Zero drift
Less than 2% of measurement range per year.
Please, refer to QAL1 documents.

Linearity error
Less than 1% of measurement range.

⁽¹⁾ This data refers to a light path of 1 m. For longer paths the maximum range is proportionally smaller.

Products are available to create shorter paths in very wide stacks.

⁽²⁾ Maximum SO₂ concentration: 5 g/m³ × m.

⁽³⁾ Maximum SO₂ concentration: 500 mg/m³ × m.

⁽⁴⁾ Detection limit of 1 mg/m³ is optional with hardware upgrade.

⁽⁵⁾ Lowest measurement range.

• Recommended monitoring path length: 1 to 5 m.

• After wet scrubbers or when particulate concentration averaged over 1 m is higher than 5 g/m³, the monitoring path length may have to be reduced.

• Max. length of fibre optic cable: please refer to product sheets P9 and P16.

Continuous Emissions Monitoring and Process Control by OPSIS

Combines the benefits of UV/FTIR DOAS and TDL technology

Best performance according to QAL 1 certification

Longest calibration interval according to QAL 1 certification

Automatic QAL 3 check as option

No sampling required, non-contact measurement system

Operates with a minimum of maintenance

Low energy consumption

Gas calibration only once per year

Internationally approved

Thousands of systems installed worldwide

Serviced by highly skilled service network

UK & Ireland Distributor



Kingfisher Business Park, London Road, Stroud, Gloucestershire, GL5 2BY, UK

Tel: +44 (0) 1453 733200 sales@et.co.uk www.et.co.uk

A07
2018 10

Please contact your OPSIS supplier to discuss your particular system requirements, including the compounds you wish to monitor. Separate product and other industrial application sheets are available. Specifications subject to change without notice.

OPSIS AB

Box 244, SE-244 02 Furulund, Sweden

+46 46 72 25 00 • info@opsis.se • www.opsis.se