



# The Sintrol Snifter

## - Next Generation of Dust Monitoring



[www.sintrolproducts.com](http://www.sintrolproducts.com)

# Broken Bag Detection

- Monitor for leaking or broken filters
- Optimize filter cleaning cycles
- Pinpoint even the smallest of leaks
- Safeguard against unwanted dust
- Satisfy local environmental regulation
- Provide real-time feedback from process
- Prevent product loss

- Low maintenance real-time dust monitoring
- No sample handling required
- Fast response to changes in process conditions
- Long-term trend monitoring
- Extremely sensitive
- UL and CSA certification, Class II Div I, Subgroups E, F & G

The brand new family of Sintrol Snifter devices brings the same reliability of the original Snifter A1 with new features and benefits to make dust monitoring easier.

The new enclosure with a thicker wall and rounder surface provides maximum durability and reliability of the instrument to withstand heavy industrial conditions.

Once installed, Snifter's automatic setup function will adjust itself to the dust flow conditions of your application and use alarm signals to notify you of bag breakages. Snifter has the necessary sensitivity to meet low levels of dust concentrations in modern fabric filters. Additionally, the quality of the measuring principle and enclosure ensure that the monitor will run continuously with minimal maintenance while withstanding vibration from the process or dust build up on the probe.

The fast response time of the Snifter enables the earliest detection of broken filter systems and helps prevent loss of expensive product to the environment.

## Snifter A2

Using the DustTool software provided with the monitor, the Snifter A2 has two independent alarm signals for applications that require more flexibility with its outputs. After completing the automatic setup function, the operator can adjust the alert and alarm level signals to meet the needs of the process. The device is equipped with a USB connection to allow easy access to DustTool.

## Snifter mA+

For those that would like a continuous trend of the filter's performance, the Snifter mA+ provides a 4-20 mA output to identify relative trends. Using DustTool, the alarm signals can be adjusted to meet the operator's needs to give indications of filter leaks or breakages.

## Snifter CB3 EXG A

The connection box CB3 EXG A is a recommended option to ensure correct installation as well as to provide an easy way to interface with the DUMO.



Features	A2 A	mA+ A
Protection category	IP65	IP65
2 adjustable outputs	•	•
RS485 and USB Interface	•	•
mA output		•
DustTool	•	•
DustLog8	x <sup>1</sup>	x
Atex 22	x	x
Class II Div I & UL certified	x	x
Wireless Interface	x	x
Connection Box	x	x
	• standard	x optional
1) For A2 DustLog 8 shows only alarm information		

Wireless model, Snifter EXG RF A, 915Mhz communicates with DustLog8 reporting software for accessing a network of Sintrol devices.  
868 MHz ISM model available.

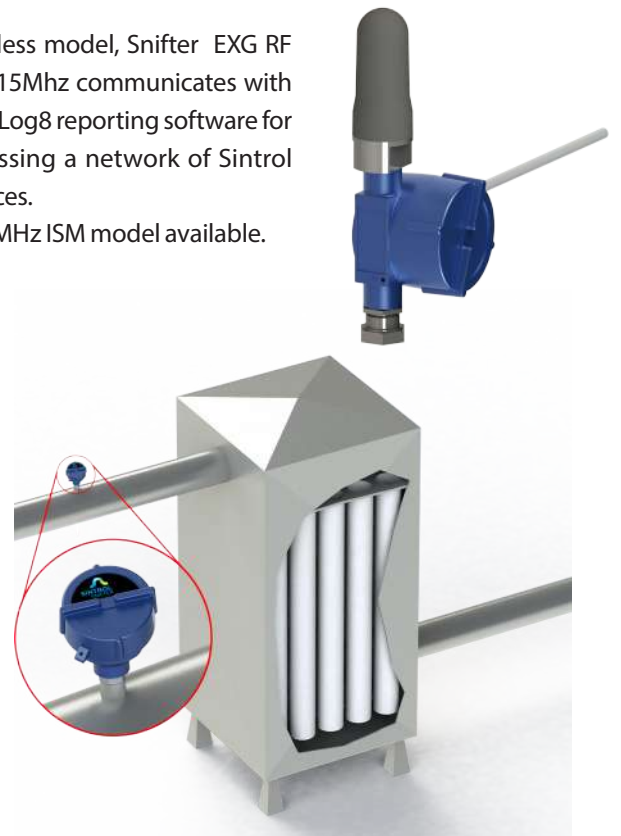

Sintrol Snifter is installed directly after the dust filtration unit to provide the fastest detection for bag breakages or deterioration.

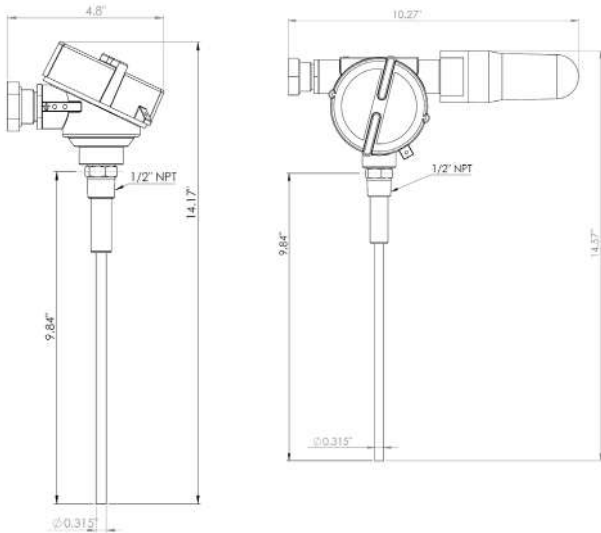

## DustLog Software

DustLog gives the plant operator complete control over the network of dust monitors. It provides a thorough and user-friendly interface for setting parameters of the network and dust monitors as well as reporting. DustLog can be connected to a dust monitor network via network router. Dustlog supports USB, RS485 (Modbus) and wireless RF.

- Comprehensive data storage and processing
- Remote access to dust monitors
- Remote access allows user to calibrate units, change alarm limits, conduct auto setup functions, configure mA outputs etc...
- Data export to third party software such as excel
- Real time monitor views of various measuring points
- Database: Microsoft SQL, Postgre SQL, SQLite



Documentation subject to change without notice

Measurement Objects	Solid particles in a gas flow
Measuring Range	From 0.1 mg/m <sup>3</sup> up to 6 g/m <sup>3</sup>
Measurement Principle	Inductive Electrification
Power Supply	12-24VDC
Power Consumption	3W
Cable Connection	2 m cable   16.4 ft cable 5-12 wires depending on model
Process Connection	- NPT 1/2" male thread - NPT 1/2" female thread welding socket (optional)
Output Signals	- Two output signals (100-280mA) - Isolated 4 - 20 mA output, mA model only
Communication Interface	- Serial communication RS485 - USB communication - Wireless communication (optional)
Communication Protocol	- Modbus RTU, (RS485) - SNT network, (USB, wireless, RS485)
Alarm Settings	- Automatic, alert: 5 x normal dust level and Alarm: 20 x normal dust level - User selectable limits
Signal Damping time	- Fixed at factory 100 s - Adjustable from 0-6000 s
Process Temperature	Max 250 °C   Max 482 °F
Pressure	Max 200 kPa   Max 29 PSI
Gas Velocity	Min 3 m/s   Min 9.8 ft/s
Humidity	Max 95% RH (non-condensing)
Ambient Temperature	- Starting -20 to +40°C   -4 to 104 °F - Running -40 to +60°C   -40 to 140 °F
Sensor Length (total /measuring)	250 mm / 185 mm   9.8" / 7.3"
Probe Material	Wetted part: Stainless steel (AISI 316L)
Process Connection	Wetted part: Stainless steel (AISI 316L)
Enclosure	Aluminium
Probe Insulation	Wetted part: PEEK
Weight	Standard model 0.7 kg   1.5 lbs
Approvals Available	UL and CSA, - Class II Div I, subgroups E, F and G



## Principle of Operation

Sintrol dust monitors are based on a unique Inductive Electrification technology. The measurement is based on particles interacting with an isolated probe mounted into the duct or stack. When moving particles pass nearby or hit the probe, a signal is induced. This signal is then processed through a series of Sintrol's advanced algorithms to filter out the noise and provide the most accurate dust measurement output.