



Enviro

Technology Services Ltd

part of  CuraTerra

DIGITEL DPA14

Low Volume Aerosol Sampler designed for EN12341:2014



- For autonomous, continuous sampling
- Automatic filter changer for 30 filters
- Constant and precise flow
- Filter diameter 47 mm
- For PM2.5 and PM10 measurements according to EN12341:2014
- TSP, PM10, PM2.5 and PM1 inlets

**EN12341: 2014
compliance verified by
TüV SÜD**

- ✓ Light weight but robust and weather proof
- ✓ Low energy consumption
- ✓ Low maintenance cost
- ✓ Easy programming with touchscreen
- ✓ Easy filter handling
- ✓ Software for easy EN12341 tests
- ✓ Wide range of options and accessories

Introduction

DIGITEL Low Volume Samplers DPA14 are fully automatic systems to sample dust and aerosol particles for later assessment and analysis (gravi-metric and analytical determination) in accordance with EN12341:2014. The sampler operation range in standard execution is 5 to 50 litres per minute (0.3 to 3m³/h). The DIGITEL LVS DPA14 has a magazine of 30 filters stretched in filter holders. They are automatically changed to the flow position at the pre-set time. The devices can be integrated in automatic monitoring systems via various interfaces. The field housing of the DIGITEL LVS DPA14 is suited for outdoor installation. It is easy to transport and because of a good sound insulation very quiet. Superior workmanship in sampler mechanics backed by the latest technical and electronic control guarantee a long lifetime and absolutely reliable operation.

Advantages

An integrated microprocessor unit controls the filter changes at the pre-set time and collects all relevant data and events. The status "work" and "pause" (filter change) can be programmed with a resolution of one minute. The time for the filter change is kept at a minimum, the automatic filter change is done within 2 seconds and the blower is started again. The constant flow of sampled air through the filter is dynamically controlled, so that this value is kept at good reproducibility and at long-term stability which keeps to a minimum of electrical power consumption. An optional auto calibration device for the autonomous calibration of the Venturi type orifice flow control is available. The mechanical components which are in contact with measuring air are coated with a highly corrosion-resistant and extremely smooth surface. The DPA14 Low Volume Sampler has different interfaces for data transmission and remote control.

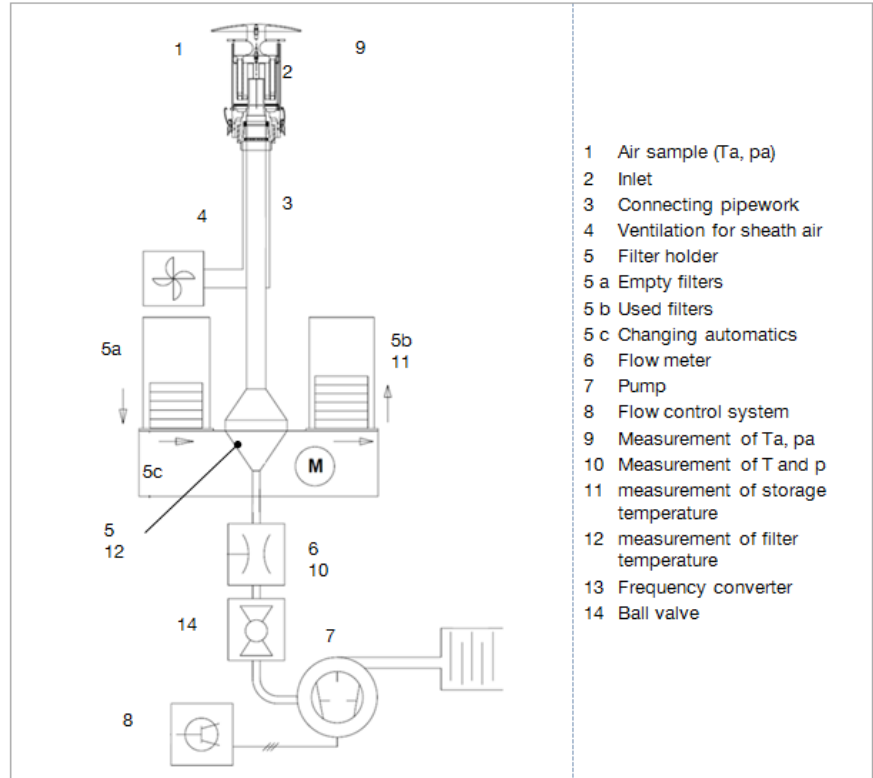

Figure 1: Design and operation flowchart

The filter magazines can be filled and emptied with one hand, no additional tools are needed. An optional barcode reader allows direct identification of the filters in the sampler.

Design and Operation

The air is sampled through a TSP/PM10 / PM2,5 / PM1 inlet, using a sampling tube. Around this tube, a protective tube allows a ventilator forced air stream as sheath air to avoid thermal effects on the sampling tube. The air flows vertically from the top to the bottom through the filter placed in the flow chamber. The upper part of the flow chamber works like a diffusor with regular cross section and ensures uniform loading of the exposed circular filter. The pressure drop across the filter is limited, so that a

rupture of damp or extremely loaded filters is prevented. The DPA14 changes the filters automatically. Behind the filter, the transported air quantity is measured by a Venturi type orifice flow meter (optionally by a flow meter with a float and double photo sensor). The blower is speed controlled, so that the air quantity keeps the set-point value with minimal power consumption. Air pressure and temperature are measured upstream of the flow meter and continuously averaged by the electronic control unit. A real-time protocol states sampling volumes yielding from the sampling time and controlled volume flow as the core information. The sampling protocol lists the effective and the standardized averaged values of pressure and temperature, volume and the operating status as well as the failure status.

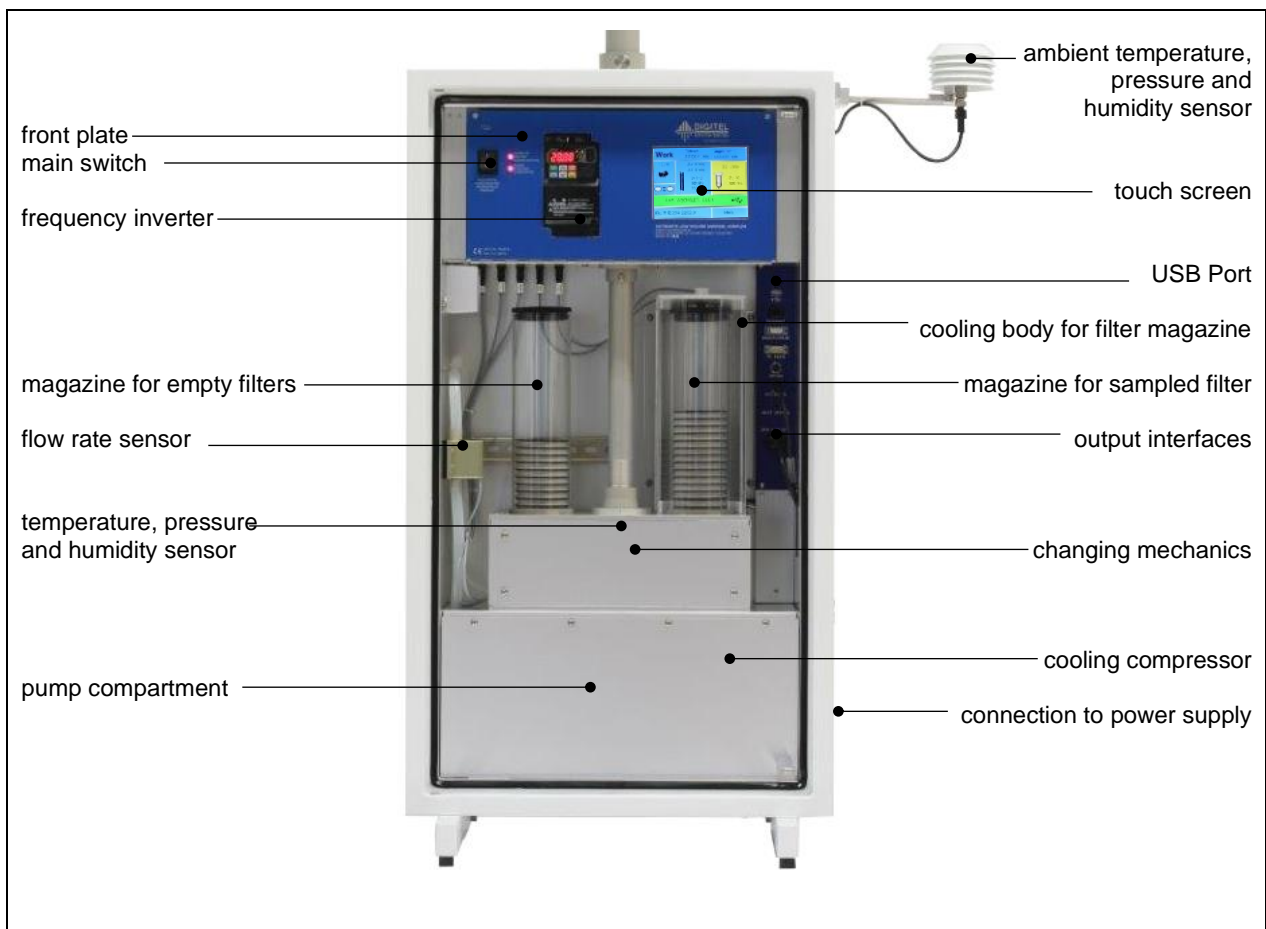

Figure 2: Components

Easy programming

The touch screen allows simple and user friendly programming. The current state of the sampling course (e.g. program status, status periods, failure indication messages) is shown on the display. In case of power failure, all settings are kept stored. Therefore, programmed filter change times are not postponed in case of meantime power interruptions.

State of the art electronics

The Digitel LVS DPA14 has a RS-232C interface which is used for data transmission with different protocols (DIGITEL-, Bayern-Hessen-Protocol, AKProtocol...) and for remote control. The internal memory has the ability to store data during two months of daily sampling. Additionally, the measuring data can be saved on a USB drive.

The USB port can also be used for software updates, which allows a simple in field update of the instrument. The DPA14 also has an Ethernet interface, which enables connections to any TCP/IP network. This allows data collection via FTP and remote control of the DPA14 (integrated HTTP-Server) as well as software updates over ethernet. An optional text message module sends alert error messages.

Superior coating

All parts that come into contact with measuring air, including filter holders, are made of aluminium and coated with a very corrosion-resistant and extremely smooth anodized surface.

Compact aluminium housing

The extraordinary compact type of construction, especially the low depth, allows that even the field equipment can be space-savily installed in a container. Together with a DIGITEL PM10 or PM2.5 inlet, the system is in accordance with the EN12341:2014 Standard.

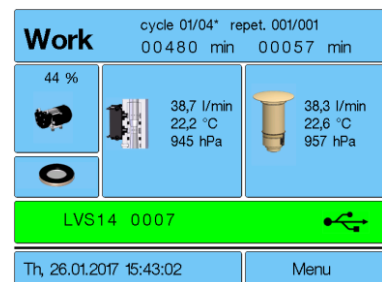

Figure 3: Touch screen

| Technical Data | |
|----------------------------------|----------------------------------------------------------------------------------------------------------------------------------|
| Flow rate | 5 – 50 l/min (Rotameter) |
| Filters | 30 round filters of d = 47 mm, flowing area d = 40 mm plus one in sampling position |
| Time programs | Work, Pause (0 to 59'999 minutes each), start time adjustable, using date and time Different sampling cycles programmable |
| Cooling capacity of compressor | 360 W |
| Mean life cycle suction unit | > 16'000 h |
| Constancy of sample flow | <2% |
| Negative pressure | Max. capacity 800 mbar, limited to -450 hPa for filter protection |
| Sensors | Ambient and flow pressure, temperature, humidity |
| Interfaces / Interface protocols | RS232C, USB, Ethernet, RS485 / DIGITEL, Bayern-Hessen, AK, TCP/IP, HTTP, FTP |
| Internal memory | 16MB |
| Power supply | 230V AC / 50-60 Hz; max. 2A/400 W |
| Heating | Inlet heating / indoor heating / reserve heating |
| Application range | -40° to 50° C; 0 % to 95 % RH (cooling option: max. 40°C for cooling below 23°C) |
| Material | All components (incl. filterholder and inlets) in the suction area are made of anodized aluminium, POM filter holders on request |

| Dimensions | |
|---------------------------------|-----------------------------------------------------------------------|
| Field housing (without inlet) | 526x 235 x 1000 mm, 40 kg (43 kg with cooling), protection class IP54 |
| Cabinet housing (without inlet) | 448 x 204 x 922 mm, 32 kg |

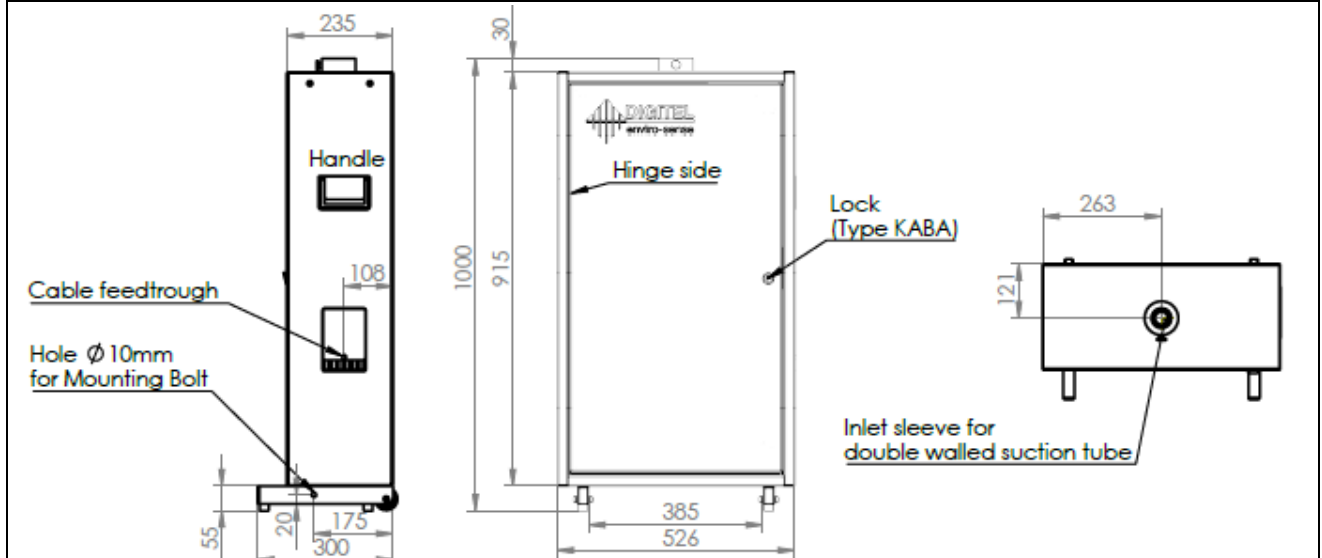

Figure 4: Dimensions of the field housing

| Features | Options | Accessories |
|-------------------------------------------------------------------------------------------------------------------------------------------------------------------------------------------------------------------------------------------------------------------------------------------------------------------------------------------------------------------------------------------------------------------------------------------|----------------------------------------------------------------------------------------------------------------------------------------------------------------------------------------------------------------------------------------------------------------------------------------------------------------------------------------------------------------------------------------------------------------------------------------------------------------------------------------------------------------------------------------|-----------------------------------------------------------------------------------------------------------------------------------------------------------------|
| <ul style="list-style-type: none"> Automatic filter change Change failure recognition Empty magazine recognition Overload cut-off Internal data memory Interchangeable filter magazines Autocalibration of orifice flow meter with rotameter flow meter Valve and software for easy tightness test according to EN:12341:2014 Venturi type orifice | <ul style="list-style-type: none"> GSM Modem for direct remote access to sampler for remote control or filter list upload Protocol printer External meteorological data collection (e.g.: wind direction and wind speed) SMS module for status and messages Delivery of single components on request Filter identification: in-built barcode reader assigns filter data to barcode on filter Filter identification: filter data stored on filter holder over RFID | <ul style="list-style-type: none"> TSP inlet PM10, PM2.5, PM1 inlets Inlet heating (regulated, ambient temperature controlled) |

Table 1: DPA14 Summary