

ABB - Los Gatos Research

High performance analysers for the measurement of trace gases, greenhouse gases and stable Isotopes.

the technology...

Off-Axis Integrated Cavity Output Spectroscopy (OA-ICOS)

All ABB-LGR analysers utilise a unique laser absorption technology called Off-Axis Integrated Cavity Output Spectroscopy (OA-ICOS). This LGR patented technique offers superior performance, value and reliability compared to cavity ringdown spectroscopy (CRDS).

Cavity enhanced absorption was first developed as an ultra-sensitive detection method by LGR founder Anthony O'Keefe in 1988 (Review of Scientific Instruments (ISSN 0034-6748), vol. 59, Dec. 1988, p. 2544-2551) in the form of cavity ringdown spectroscopy (CRDS). While innovative, this first-generation technique requires sub-nanometer alignment of its internal optics, which translates directly into limitations in terms of high cost, reliability, and vulnerability to vibrations and temperature/pressure changes.

To overcome these drawbacks, scientists at LGR developed, and subsequently patented, a fourth-generation cavity enhanced laser absorption technology called OA-ICOS. This approach delivers superior performance, yet is orders-of-magnitude less sensitive to internal alignment of components and to variations in local temperature and pressure. As a result, OA-ICOS is ideal for use in commercial instruments for even the most demanding applications in remote locations.

The inherent advantages of OA-ICOS technology make ABB-LGR trace gas and stable isotope analysers the best choice, whatever the application.

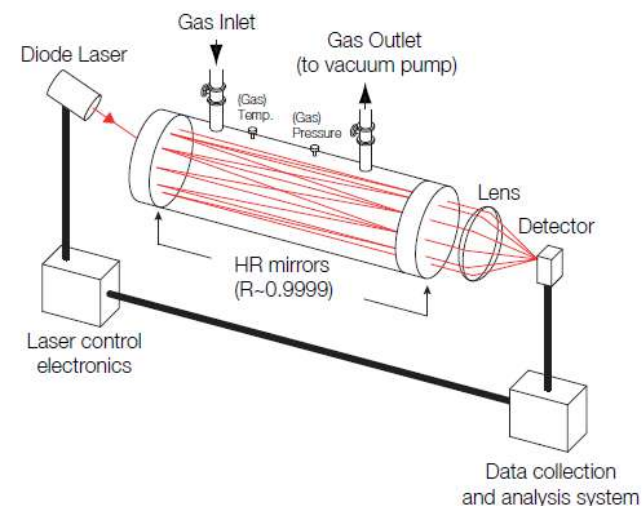

- **Parts-per-billion level precision** – thanks to advanced signal processing and a folded optical path of several kilometres.
- **Wide linear dynamic range** – due to the fact that absorption is measured directly.
- **Field serviceable** – the cavity mirrors can be removed, cleaned and replaced quickly with minimal training.
- **Robust** – because OA-ICOS is not dependent on ultra-precise optical alignment, ABB-LGR analysers are less sensitive to shocks and vibration than competitor instruments.
- **Low running costs** – ABB-LGR analysers do not require any carrier gases or reagents, and do not need to be recalibrated often.
- **UK based technical support** – ET's UK based engineers can provide same-day technical advice, and analysers can be repaired and serviced at our HQ in Gloucestershire.

unmatched reliability

ABB-LGR analysers combine state-of-the-art performance with robust operation and unmatched reliability, enabling continuous operation in challenging environments, as well as in mobile (truck, ship, aircraft) and remote applications.

For these reasons, ABB-LGR trace gas and stable isotope analysers deliver state-of-the-art precision and unmatched reliability whether in the laboratory, in a helicopter, or at an unmanned Arctic monitoring site.



exceptional value

All ABB-LGR analysers deliver exceptional value by providing superior performance over any other technology, while still remaining an economical instrument.

By employing this simpler, more robust technology, ABB-LGR trace gas and stable isotope analysers deliver state-of-the-art precision and accuracy for a cost that is approximately half that of the nearest competitor.

maintenance

All ABB-LGR analysers are designed for simple field maintenance, avoiding the factory return that all competitive instruments require, even for simple optics cleaning.

ABB-LGR analysers reduce the downtime impact of accidental optics contamination to only minutes rather than the days or weeks required by conventional CRDS systems. Furthermore, in ABB-LGR instruments, the laser beam spot pattern covers practically the entire cavity mirror, in contrast to conventional CRDS, which only uses a small area in the center of the mirror. As a result, ABB-LGR instruments are much less affected by the presence of dust than conventional CRDS systems and thus require far less frequent service.

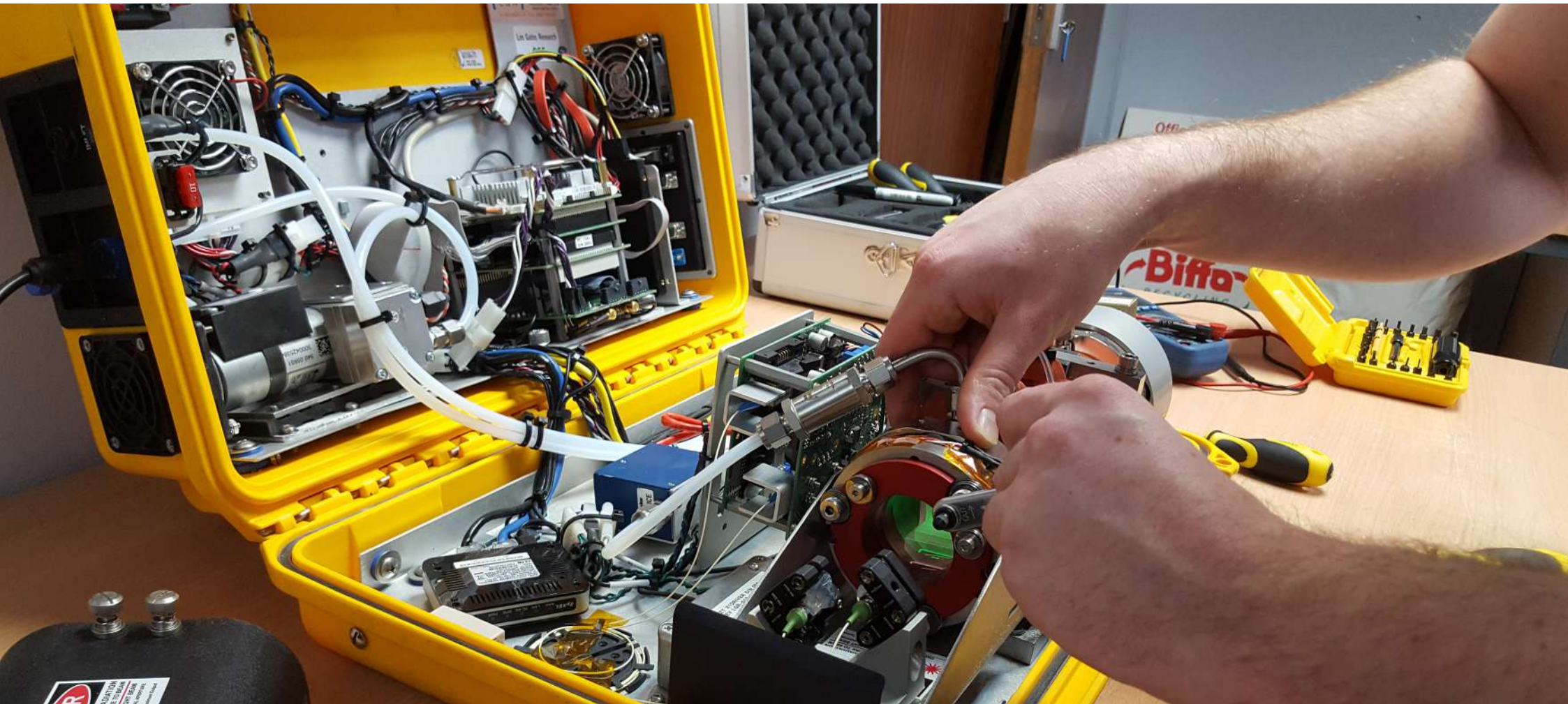

Acetylene (C_2H_2)

Ammonia (NH_3)

Carbon Dioxide (CO_2)

Carbon Monoxide (CO)

Carbon Sulfide (OCS)

Ethane (C_2H_6)

Deep-Water Gas

Dissolved Gas Extraction

Hydrogen Chloride (HCl)

Hydrogen Fluoride (HF)

Hydrogen Sulfide (H_2S)

Industrial Emissions

Methane (CH_4)

Nitrous Oxide (N_2O)

Oxygen (O_2)

VOC

Water (H_2O)

trace gas

Trace gas and isotopic analysers from ABB-LGR are available in rackmount and benchtop configuration for use in the laboratory.



isotopes

ABB-LGR's isotope analysers can be used everywhere. These analysers use ABB-LGR's Off-axis ICOS technology, a fourth-generation cavity enhanced absorption technique. Off-axis ICOS has many advantages over conventional Cavity Ringdown Spectroscopy (CRDS) having a much shorter measurement time (yielding a faster data rate), and not requiring expensive and power consuming auxiliary components.

The analyser includes an internal computer that can store data practically indefinitely on its internal hard drive (for applications requiring unattended longer term operation), and send real-time data to a data logger through its analog and digital (RS232) outputs. In addition, all ABB-LGR analysers may be fully accessed and controlled over the internet for remote diagnostics and unattended operation.

Liquid Water Isotope Analyser (LWIA)

The LWIA is ideal for a wide variety of hydrological, analytical, and biological applications that involve measurements of fresh water, seawater, and other liquids.

It's able to provide measurements of $\delta^{18}\text{O}$, $\delta^{17}\text{O}$ and $\delta^2\text{H}$ of water in liquid (including wines) and discrete vapour samples with unsurpassed performance.

*The LWIA is also available as an ultraportable **U-LWIA-915***

Fast and accurate analyser for measurement of $\delta^2\text{H}$ and $\delta^{18}\text{O}$ in liquid water – anywhere



The Dissolved Gas Extraction System (DGES) allows continuous concentration measurements of dissolved gases in water and other liquids in real time.

This novel tool, when combined with one or more ABB-LGR trace gas analysers, can replace time consuming head-space equilibration processes and complex shower-head systems. This allows new research opportunities, including measuring gas seepages from ocean floor; monitoring water quality of oceans, lakes, rivers, and fish farms; quantifying surface-gas exchange processes in lakes and monitoring dissolved gases in wastewater treatment plants.



High precision N₂O isotopic analysers



*Isotopic N₂O Analyser -
EP QC Benchtop*

The GLA451-N2O12 and GLA451-N2O13 enhanced performance quantum cascade (EP QC) benchtop analysers provide continuous and precise analysis of the site-specific isotopic ratios $\delta^{15}\text{N}$, $\delta^{15}\text{N}$, $\delta^{18}\text{O}$ and $\delta^{17}\text{O}^*$ of N₂O directly and without any preconcentration or water cooling.

Features and benefits

- Simultaneous measurements of N₂O and its stable isotopes
- Highest accuracy, precision and low drift
- Installed and operational in minutes
- Batch operation option via gas autoinjector or manually from a syringe
- Robust to cross-interferences
- Extremely high dynamic range
- Unsurpassed reliability
- Real-time diagnostics
- N₂O measurement rates selectable up to 10 Hz with fast-flow mode (optional dual use)

High precision CO₂ isotopic analysers

When making isotopic carbon dioxide measurements, scientists require:

- accurate measurements over a wide range of mole fractions
- high precision
- ability to report reliable values even if mixing ratios are rapidly changing
- portability
- user-friendly interface
- low drift
- insensitivity to H₂S, NH₃ as well as methane and other hydrocarbons

ABB's carbon dioxide isotope analysers meet all of these requirements. In addition, the availability of many value-added options extends the abilities of these units to include discrete samples (collected in bags or vials) and to automatically handle multiple inlet sources.

ABB-LGR range of Isotopic CO₂ analysers come in the following configurations:

- **Ultraportable - LGR-ICOS™ GLA132-CCIA2**
- **EP Rackmount - LGR-ICOS™ GLA331-CCIA2**
- **EP Benchtop - LGR-ICOS™ GLA431-CCIA2**
- **EP QC Benchtop - GLA351-CCIA3**



*GLA351-CCIA3
CO₂ isotopic analyser -
EP QC benchtop*

available in four configurations



Microportable

ABB-LGR's new ground-breaking Microportable Greenhouse Gas analyser reports fugitive emissions measurements of methane and carbon dioxide and water vapour simultaneously in a 6kg, handbag-size, package that is compact and crushproof.



Microportable Greenhouse Gas analyser (GLA131-GGA)

Ultraportable

The ground-breaking, "Ultraportable" line of analysers from ABB/LGR are designed for environmental and industrial applications.

ABB-LGR ultraportable analysers are small and lightweight, requiring little power. With sensitivities in the parts-per-billion range, they provide simultaneous, continuous measurements of multiple trace gases.

Applications include field, soil, and air quality studies; compliance monitoring; natural gas leak detection; and eddy accumulation.



Ultraportable Greenhouse Gas Analyser (GLA132-GGA)

Rackmount

High performance rackmount enclosures for general purpose applications.

Highly sensitive, precise, accurate, interference free and wide dynamic range analytical performance for fast, reliable and repeatable results.



Rackmount Greenhouse Gas Analyser (GLA231-GGA)

Enhanced Performance Rackmount

Sensitive, precise, accurate, highly linear (wide dynamic range) and fast.

Temperature controlled rackmount analysers for challenging applications requiring ultimate long-term stability.



Enhanced-Performance Rackmount Greenhouse Gas Analyser (GLA331-GGA)

Highly sensitive drone-based **gas leak detection** and **greenhouse gas** measuring system **HoverGuard™**

The HoverGuard detects natural gas leaks around hard-to-reach sites such as bridges, high-rise buildings, areas with right-of-way restrictions or vegetation coverage, and pipelines.

HoverGuard uses patented cavity-enhanced laser absorption spectroscopy to detect methane with a sensitivity and precision more than 1000 times higher than conventional leak detection tools.

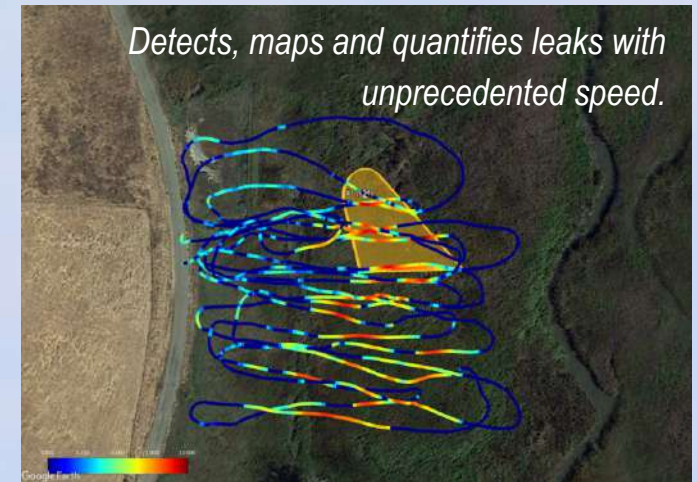

Weight <3kg



The cloud-connected, multi-gas solution is also the first of its kind to quantify the three most important greenhouse gases methane, carbon dioxide and water vapour continuously while flying.

applications

- Laboratory measurements
- Gas tracer experiments
- Soil flux chamber studies
- Eddy covariance
- Airborne measurements
- Natural gas leak detection
- And many more!



Other products



Visit our website to download other product brochures www.et.co.uk



CONTACT US

Kingfisher Business Park
London Road
Stroud
Gloucestershire
GL5 2BY

info@et.co.uk

+44 (0) 1453 733200

www.et.co.uk

